



## WARN Industrial Winch

**Model**

**Part Number**

**Motor Type**

**Olympus 25S-9X12-M-BLK Manual Clutch**

**84674**

24 Volt Permanent Magnet



The Olympus is the world's most powerful and efficient electric winch. This lightweight and compact winch is equipped with an Axial Flux Permanent Magnet Motor that provides amazing power and extreme duty cycle that rivals hydraulic performance. Waterproof construction and superior corrosion resistance along with an overload Interrupt switch, provide excellent durability, safety, and performance.

- \*Remote Control Assembly, 32' included
- \*HAWSE Fairlead included
- \*100' x 5/8" WARN Synthetic Rope Assembly included

### Accessories

**Description:**

**Part Number**

### Engineering Data

Rated Pulling Force:	25000 lbf	11340 kgf
Drum Barrel Diameter:	5.0 in	127 mm
Drum Flange Diameter:	9.00 in	229 mm
Distance Between Flanges:	12.0 in	305 mm
Recommended Maximum Wire Rope Diameter:	5/8 in	15.9 mm
Recommended Minimum Wire Rope Breaking Strength:	40000 lbf	18144 kgf
Approximate Shipping Weight:	204.0 lb	92.5 kg
Duty Cycle (intermittent per SAE J706 section 6.2):	N/A	N/A
Mounting Bolt Torque:	80 ft*lbf	108 N*m
Maximum Layers of Wire Rope:	3	
Gear Reduction:	216:1	
Brake Type:	Spring Applied Disk	
Contactor / Remote Type:	Industrial contactor with 32' (9.8m) heavy duty remote	

### Drum Rotation

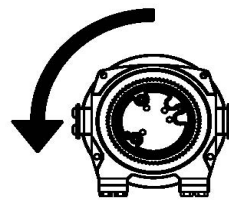

Viewed from Motor End

### Standards Compliance

N/A

### Performance By Layer- 5/8" (15.9 mm) dia. rope

Drum Layer	Line Load *			No Load Line Speed		Drum Capacity	
	lbf	kgf	kN	ft/min	m/min	ft	m
1	25000	11340	111.2	8.4	2.6	25	7.6
2	20455	9278	91.0	10.2	3.1	56	17.1
3	17308	7851	77.0	12.1	3.7	100	30.5

\* Never exceed the Rated Pulling Force. Installation of a Rated Capacity Limiter is recommended.

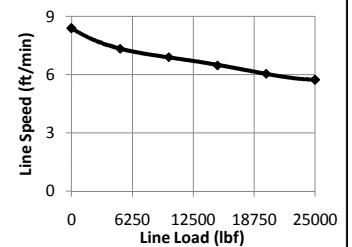

### First Layer Performance

Line Load		Current Draw	Line Speed		Duty Cycle
lbf	kgf	Amps	ft/min	m/min	min/10min
0	0	7.0	8.4	2.6	N/A
5000	2268	60.0	7.3	2.2	N/A
10000	4536	107.0	6.9	2.1	N/A
15000	6804	157.0	6.5	2.0	N/A
20000	9072	208.0	6.1	1.8	N/A
25000	11340	258.0	5.7	1.7	N/A

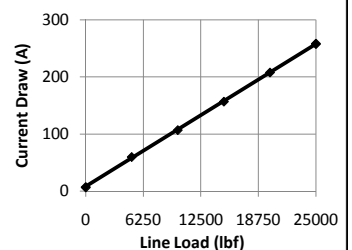

**WARN INDUSTRIES, INC**  
Industrial Products

Customer Service (North America): 1.800.543.9276  
Customer Service (International): 1.503.722.3008  
FAX: 1.503.722.3000 www.warn.com

12900 S.E. Capps Road,  
Clackamas, OR USA 97015



# WARN Industrial Winch

Model	Part Number	Motor Type
Olympus 25S-9X12-M-BLK Manual Clutch	84674	24 Volt Permanent Magnet

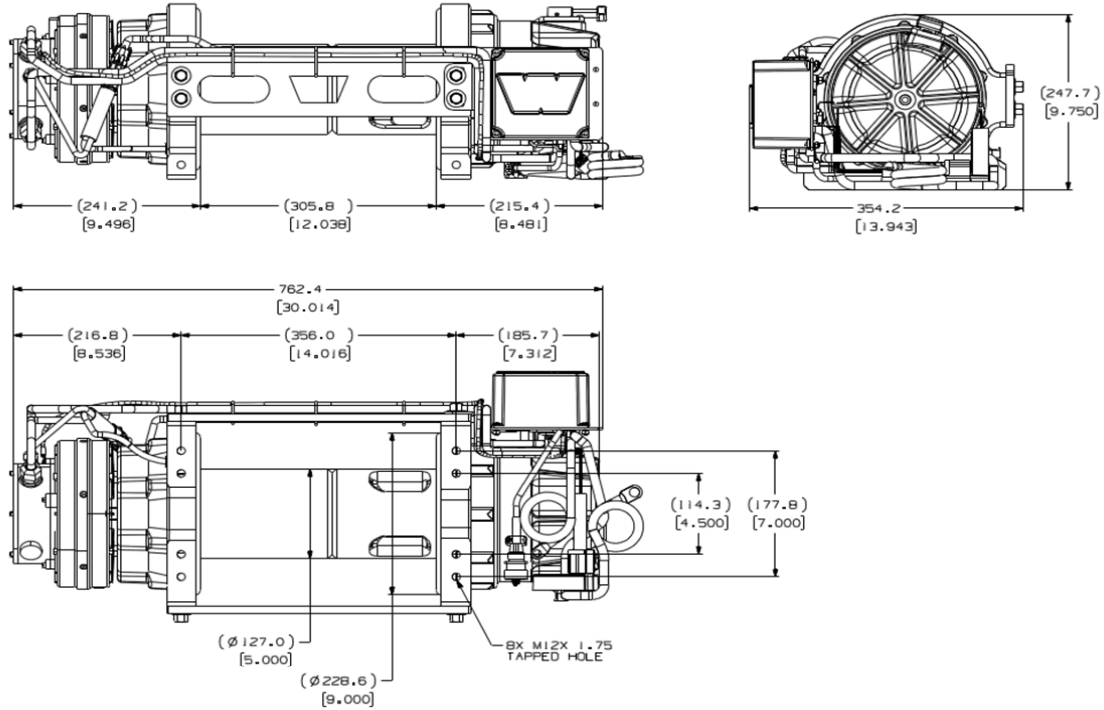

Clutch housing may be rotated in 45 degree increments.

Units are given in [inches] millimeters, unless otherwise specified

Recommended Mounting- Always Observe Correct Drum Rotation			Electrical System Specifications
Pull from bottom of winch	Pull from bottom of winch	Pull from top of winch	650 CCA Battery Minimum
			All electrical connections must be clean and tight
Feet down	Feet forward	Feet forward	
Pull from top of winch	Pull from top of winch	Pull from top of winch	<b>Electrical System Wiring Schematic</b>
			See Operators Manual P/N 86607
Feet down without angle brace	Feet down with angle brace	Angle Braces Only	Notes:

**WARN INDUSTRIES, INC**  
Industrial Products

Customer Service (North America): 1.800.543.9276  
Customer Service (International): 1.503.722.3008  
FAX: 1.503.722.3000 www.warn.com

12900 S.E. Capps Road,  
Clackamas, OR USA 97015