



WARN Industrial Winch

Model

Part Number

Motor Type

Olympus 22W-8X8-A-CRC Air Clutch

83616

24 Volt Permanent Magnet



The Olympus is the world's most powerful and efficient electric winch. This lightweight and compact winch is equipped with an Axial Flux Permanent Magnet Motor that provides amazing power and extreme duty cycle that rivals hydraulic performance. Waterproof construction and superior corrosion resistance along with an overload interrupt switch, provide excellent durability, safety, and performance.

- *Remote Control Assembly, 32' included
- *Wire Rope Tension Kit included
- *Fairlead included
- *Winch comes with CARC coating
- *75' x 1/2" WARN Construct 6 Wire Rope Assembly included

Accessories

Description:

Part Number

Engineering Data

Rated Pulling Force:	22000 lbf	9979 kgf
Drum Barrel Diameter:	5.0 in	127 mm
Drum Flange Diameter:	8.0 in	203 mm
Distance Between Flanges:	8.0 in	203 mm
Recommended Maximum Wire Rope Diameter:	1/2 in	12.7 mm
Recommended Minimum Wire Rope Breaking Strength:	33600 lbf	15241 kgf
Approximate Shipping Weight:	236.0 lb	107.0 kg
Duty Cycle (intermittent per SAE J706 section 6.2):	N/A	N/A
Mounting Bolt Torque:	80 ft*lb	108 N*m
Maximum Layers of Wire Rope:	3	
Gear Reduction:	216:1	
Brake Type:	Spring Applied Disk	
Contactor / Remote Type:	Industrial contactor with 32' (9.8m) heavy duty remote	

Drum Rotation

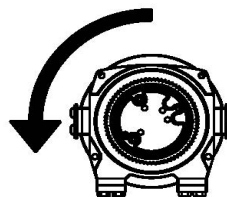

Viewed from Motor End

Standards Compliance

N/A

Performance By Layer- 1/2" (12.7 mm) dia. rope

Drum Layer	Line Load *			No Load Line Speed		Drum Capacity	
	lbf	kgf	kN	ft/min	m/min	ft	m
1	22000	9979	97.9	8.4	2.6	21	6.4
2	18615	8444	82.8	9.3	2.8	45	13.7
3	16133	7318	71.8	10.7	3.3	75	22.9

* Never exceed the Rated Pulling Force. Installation of a Rated Capacity Limiter is recommended.

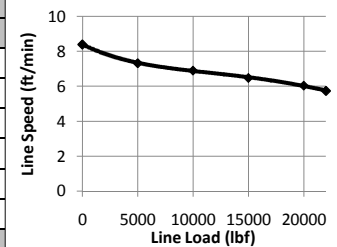

First Layer Performance

Line Load		Current Draw	Line Speed		Duty Cycle
lbf	kgf	Amps	ft/min	m/min	min/10min
0	0	7	8.4	2.6	N/A
5000	2268	60	7.3	2.2	N/A
10000	4536	107	6.9	2.1	N/A
15000	6804	157	6.5	2.0	N/A
20000	9072	208	6.1	1.8	N/A
22000	9979	227	5.7	1.7	N/A

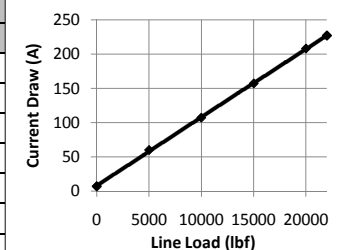

WARN INDUSTRIES, INC
Industrial Products

Customer Service (North America): 1.800.543.9276
Customer Service (International): 1.503.722.3008
FAX: 1.503.722.3000 www.warn.com

12900 S.E. Capps Road,
Clackamas, OR USA 97015



WARN Industrial Winch

Model	Part Number	Motor Type
Olympus 22W-8X8-A-CRC Air Clutch	83616	24 Volt Permanent Magnet

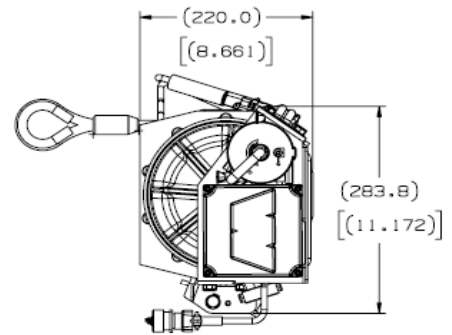
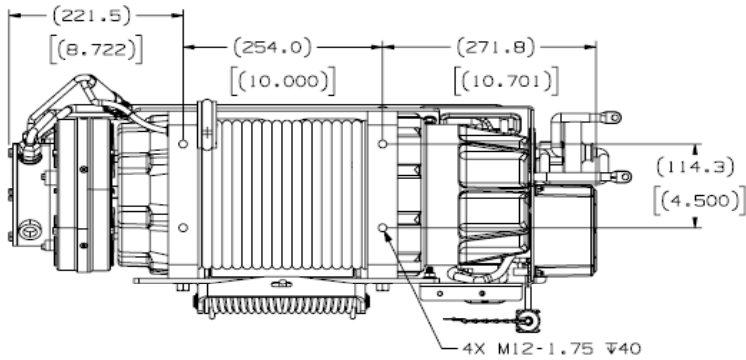
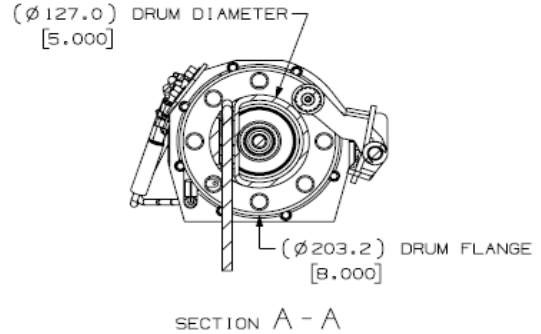
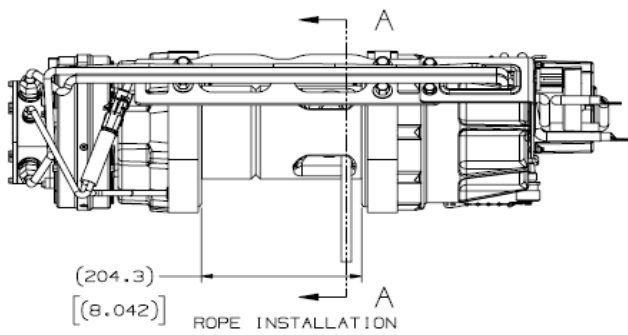

Units are given in [inches] millimeters, unless otherwise specified

Recommended Mounting- Always Observe Correct Drum Rotation

Electrical System Specifications

Pull from bottom of winch

Pull from bottom of winch

Pull from top of winch

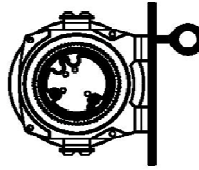
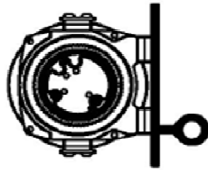

Feet down

Feet forward

Feet forward

Pull from top of winch

Pull from top of winch

Pull from top of winch

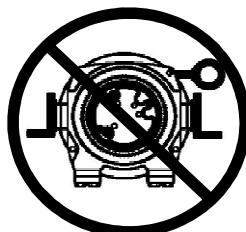
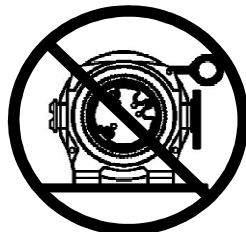
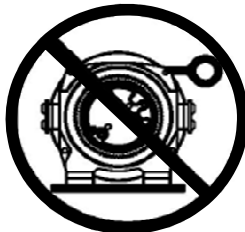

Feet down without angle brace

Feet down with angle brace

Angle Braces Only

650 CCA Battery Minimum
All electrical connections must be clean and tight

Electrical System Wiring Schematic

See Operators Manual P/N 85221

Notes:

WARN INDUSTRIES, INC
Industrial Products

Customer Service (North America): 1.800.543.9276
Customer Service (International): 1.503.722.3008
FAX: 1.503.722.3000 www.warn.com

12900 S.E. Capps Road,
Clackamas, OR USA 97015