



WARN Industrial Hoist

Model

Part Number

Motor Type

HY3000-CCW

36948

Hydraulic
3.0 ci
(50 cc)

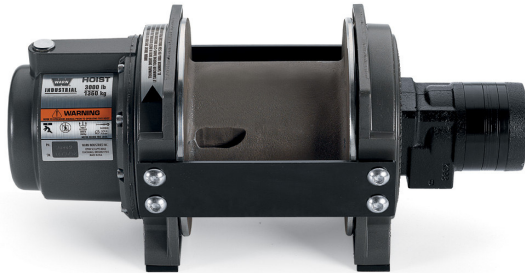

The HY3000 hoist combines a powerful and efficient hydraulic motor with robust sealing and our proven 2-stage all metal geartrain. Permanent grease lubrication means years of trouble free service. All WARN hoists incorporate an automatic mechanical brake that holds full rated load. The durable powder coated finish stands up to the elements and looks great. The HY3000 hoist is built on a large frame with a cast aluminum drum for plenty of wire rope capacity.

Accessories

Description:	Part Number
Wire Rope Assy-5/16" x 125ft	25987
Wire Rope Assy-5/16" x 100ft	24900
Wire Rope Assy-5/16" x 80ft	15276
Wire Rope Assy-5/16" x 75ft	24899
Wire Rope Assy-5/16" x 50ft	38309

*Clockwise model shown in photo. Always observe correct drum rotation.

Engineering Data

Rated Capacity:	3000 lbf	1361 kgf
Drum Barrel Diameter:	5.31 in	135 mm
Drum Flange Diameter:	8.9 in	226 mm
Distance Between Flanges:	5.94 in	151 mm
Recommended Maximum Wire Rope Diameter:	5/16 in	7.9 mm
Recommended Minimum Wire Rope Breaking Strength:	10540 lbf	4781 kgf
Approximate Shipping Weight:	70 lb	31.8 kg
Duty Cycle (intermittent per SAE J706 section 6.2):	N/A ft	N/A m
Mounting Bolt Torque:	35 - 40 ft*lb	47 - 54 N*m
Maximum Layers of Wire Rope:	4	
Gear Reduction:	21:1	
Brake Type:	Automatic Disc	

Drum Rotation

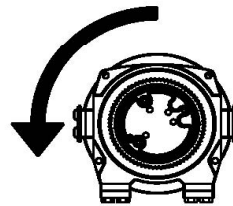

Viewed from Motor End

Standards Compliance

- CE Machinery Directive 98/37/EC and 2006/42/EC
- ASME B30.5

Performance By Layer

Drum Layer	Line Load *			Line Speed at 10 GPM		Drum Capacity	
	lbf	kgf	kN	ft/min	m/min	ft	m
1	3000	1361	13.3	43.0	13.1	25	7.6
2	2700	1225	12.0	47.0	14.3	54	16.5
3	2454	1113	10.9	52.0	15.8	85	25.9
4	2250	1021	10.0	56.0	17.1	119	36.3

* Never exceed the Rated Capacity. Installation of a Rated Capacity Limiter is recommended.

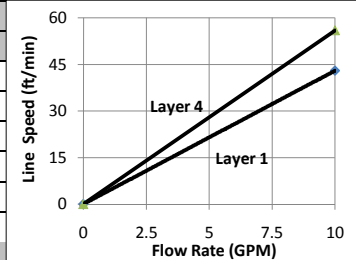

First Layer Performance

Line Load		Pressure Drop at 5 GPM		Pressure Drop at 10 GPM		Duty Cycle
lbf	kgf	psi	BAR	psi	BAR	min/10min
0	0	95	6.6	200	13.8	5.0
600	272	300	20.7	500	34.5	3.4
1200	544	600	41.4	850	58.6	2.5
1800	816	900	62.1	1200	82.7	2.1
2400	1089	1200	82.7	1500	103.4	1.7
3000	1361	1550	106.9	1950	134.5	1.5

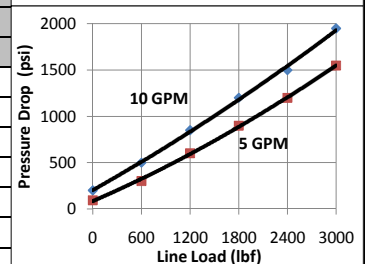

WARN INDUSTRIES, INC
Industrial Products

Customer Service (North America): 1.800.543.9276
Customer Service (International): 1.503.722.3008
FAX: 1.503.722.3000 www.warn.com

12900 S.E. Capps Road,
Clackamas, OR USA 97015



WARN Industrial Hoist

Model	Part Number	Motor Type
HY3000-CCW	36948	Hydraulic 3.0 ci (50 cc)

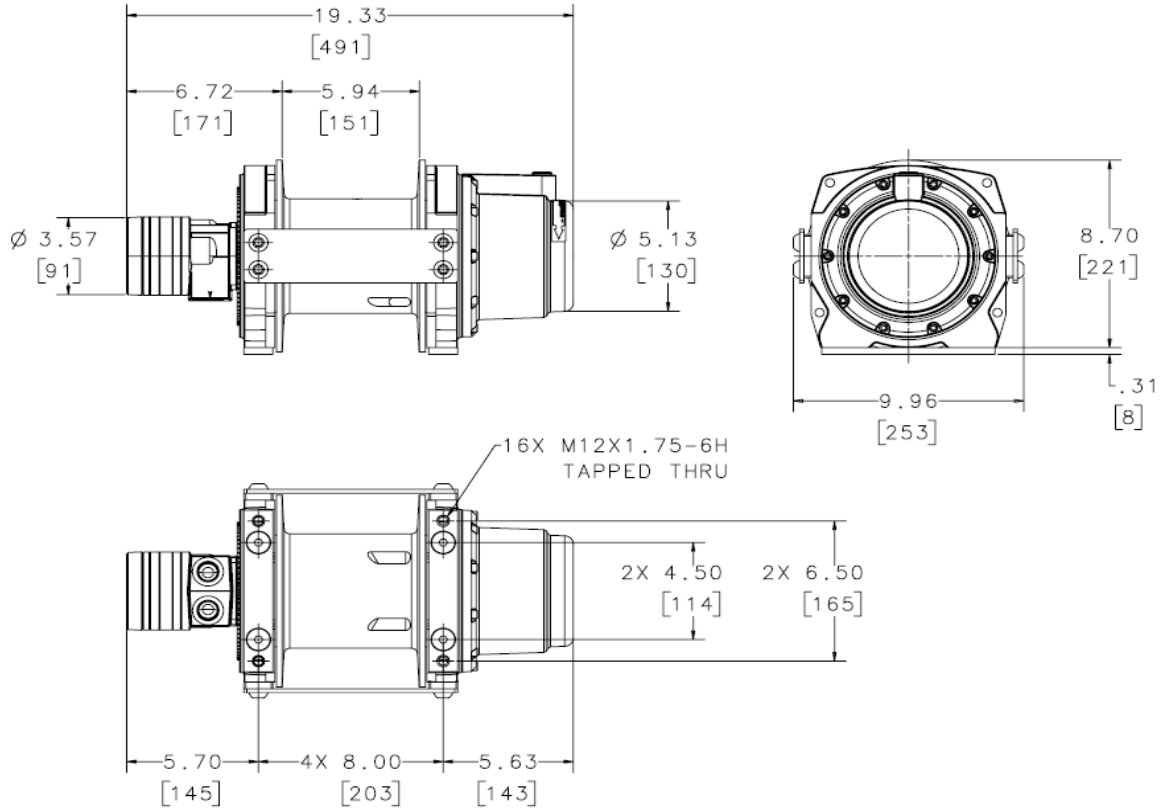

Units are given in inches [millimeters], unless otherwise specified

Recommended Mounting- Always Observe Correct Drum Rotation

Hydraulic System Specifications

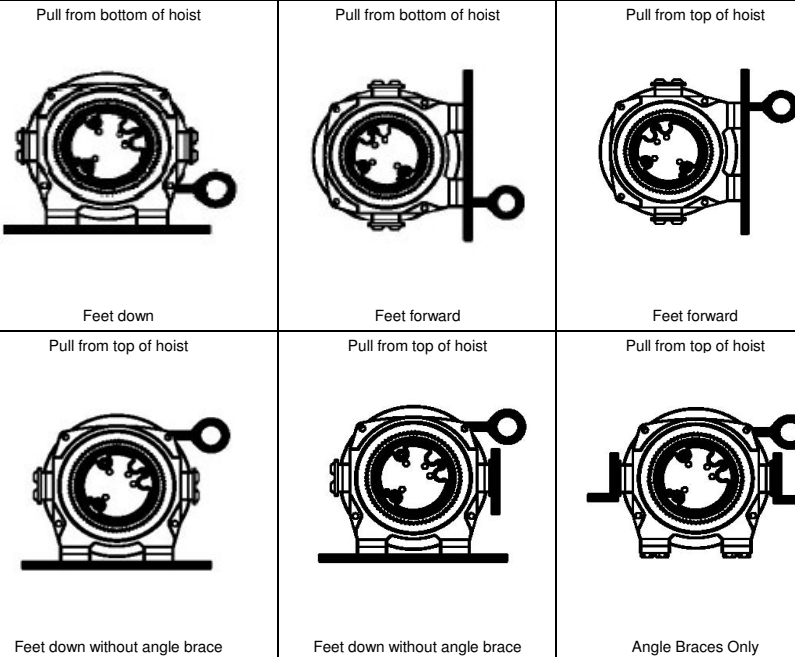

Maximum System Pressure:	1950 psi	134 BAR
Maximum Motor Pressure Drop:	1950 psi	134 BAR
Maximum Rated Input Flow:	10 GPM	37.9 LPM
Control Valve Type:	3-position, 4-way, spring return, closed center (cylinder spool)	

Control Valve Schematic

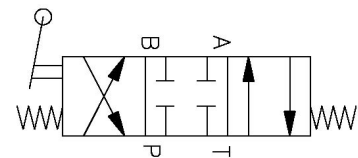

Notes:

WARN INDUSTRIES, INC
Industrial Products

Customer Service (North America): 1.800.543.9276
Customer Service (International): 1.503.722.3008
FAX: 1.503.722.3000 www.warn.com

12900 S.E. Capps Road,
Clackamas, OR USA 97015